



# Product Data Sheet

## Wall Mounted AWK10N4L2

List: \$4,408

- 1,800W electric heat
- R410a
- LCDI power cord
- 230V



### SAFETY WARNING

Only qualified professionals should install and service this equipment. Improperly installed or modifications by an unqualified person could result in death or serious injury. When working on the equipment, observe all precautions in the installation manual and labels attached to the equipment.



# Contents

<b>Key features</b>	<b>3</b>
<b>Technical requirements</b>	<b>4</b>
Louver specifications	4
AIO wall mounted specifications	4
<b>Exploded view</b>	<b>5</b>
<b>Technical specifications</b>	<b>6</b>
<b>Airflow</b>	<b>7</b>
<b>Testing procedure</b>	<b>8</b>
AIO is not a PTAC	8
AIO is not a room air conditioner	8
<b>AWK10N4L2 Submittal</b>	<b>9</b>
<b>Dimensions</b>	<b>10</b>
<b>Clearances</b>	<b>11</b>
<b>Wiring diagram</b>	<b>12</b>
<b>Mounting template</b>	<b>13</b>

AIO Wall Mounted units are slim and sleek. The wall-mounted unit can be mounted high or low with a factory-supplied bracket, making installation quick and simple. An electronically controlled louver with an auto-swing function distributes airflow comfortably and uniformly. Wall-mounted units are ideal for any area with free wall space. The onboard touch controller simplifies use and installation. A special adapter enables the unit to be installed perpendicular to an outside wall.

**Ephoca is constantly innovating and improving its products and reserves the right to modify product design and specifications without notice and without incurring any obligations.**

Ephoca is the US subsidiary of Innova SRL - Via 1° Maggio, 8 - 38089 Storo (TN) Italy.

© 2023 Ephoca. All rights reserved.

# Key features

## ■ No outdoor unit

The single package design means no outdoor unit, freeing up space on rooftops and at ground level and enabling installations in buildings without space for an outdoor unit.

## ■ BLDC inverter compressor

The state-of-the-art BLDC inverter compressor operates efficiently, quietly, and with minimal vibration. AIO is ideal for any room or area that requires between 4,000 and 9,000 BTU.

## ■ High-efficiency ECM fans with auto ESP

High-efficiency ECM fans enable efficient and quiet operation as the EC motor can ramp up or down depending on the need. Automatically adjusted external static pressure ensures correct airflow.

## ■ Cold climate heat pump

The heat pump with efficiently function down to 5°F outdoors.

## ■ 1,800 Watt electric heat

The electric heat works in conjunction with the heat pump when the heat pump has insufficient power.

## ■ Intelligent defrosting

AIO's intelligent defrosting system means more time heating and less time on reverse cycle defrost.

## ■ Coil cooling system

The condensate mister system drizzles the condensate on the outdoor heat exchanger coils, lowering the coil's temperature and increasing efficiency and performance.

## ■ Quiet

With whisper-quiet operation as low as 27 decibels, the occupant will barely notice AIO is operating.

## ■ No outside noise infiltration

AIO has the lowest STC and OITC rating among comparable units. This means less outside noise intruding into the room day and night.

## ■ Versatile on/off options

AIO's low voltage connection enables connection to any occupancy system, key-card, window sensors, fire alarms, etc.; As long as it can send a signal to AIO via low voltage, the unit can be easily turned on or off.

## ■ Corrosion protection

AIO comes standard with corrosion protection, assuring many years of trouble-free performance.

## ■ Minimal clearances and compact footprint

AIO's compact form with no line sets means there is no need to access the sides of the unit. Mount units with as little as 3/4 inch clearance on all sides. Compact footprints take up minimum space.

## ■ Leak protection

A drain alarm will activate if the drain becomes clogged, and the system will be shut off, preventing water damage.

## ■ Easy to service

AIO can be easily maintained and repaired from the front of the unit without having to remove the unit from the wall. AIO can also be quickly swapped out with a replacement, reducing downtime.

## ■ Versatile controls

AIO includes an iOS and android app and an onboard touch controller. AIO can be used with optional wall-mounted controllers, including a TFT with 7 day program and third-party controllers from any company using the optional 3rd party kit. An optional BACnet and Modbus module enables interfacing with building management systems

## ■ 10-Year limited warranty

An industry-leading ten-year limited on-site warranty provides peace of mind. One full-year parts and labor. Nine-year parts and a full ten-year parts and labor on the sealed system, including the compressor.

# Technical requirements

## AIO wall mounted specifications

Note: Refer to the full specifications for detailed information about the list of specifications.

- An electrical supply with a grounded 3-prong receptacle.
- The power supply circuit is installed in accordance with the current edition of NEC (ANSI/NFPA 70) and local codes and ordinances. Note: Always consult local and national electric codes.
- Voltage rating of 60 Hz, 208-230V single phase.
- Interior clearances as follows:
  - Sides of unit to wall: 1"
  - Bottom of unit to floor 1"
  - Top of unit to any obstruction: 3.5"
- Unblocked vents on the exterior and no obstacles within 36".
- Properly installed insulated condensate drain line with a minimum of 30% slope if an external drain. If using an external drain on a low floor, ensure that end of drain is above the maximum height of snow buildup. An internal drain is highly recommended.
- Approved louvers installed with best practices to ensure no water into the wall assembly.
- 6" or larger diameter ducts through the wall which protrude 1/8" into the unit's EPDM backing to ensure a tight seal.
- The unit must be perfectly level on the vertical and horizontal axis.
- The unit must be tight to the wall, with zero leakage between the external ducts and the unit. Use insulating material if wall is not level.
- Properly affixed wall bracket to wall studs or other supporting material.

## Louver specifications

AIO Wall Mounted units can be vented through all kinds of custom and creative solutions. The possibilities are endless, from perforated panels to custom louvers.

There are two critical factors in selecting and sizing a solution that will work with AIO Wall Mounted units.

- **Free area:** This area on a louver/grille is open for the air to flow through. The louver, perforated panel, or other solution must have at least the amount of free area as required in the specifications below in the plenum from the unit so that ample air can enter and exit the condenser chamber. A more restrictive solution with a smaller free area can be utilized by enlarging the louver and plenum until the required free area is achieved.

**The minimum free area required is .21 sq feet for the intake vent and .21 sq feet for the exhaust vent.**

- **Pressure drop:** Pressure drop is the resistance the louver/grille creates against the airflow. This resistance can create heat build-up inside the condenser portion, causing the compressor to overheat and shut down. A solution with a higher pressure drop than specified can be utilized by enlarging the louver and plenum until the pressure drop is within specification.

**The maximum total pressure for the intake and exhaust louvers combined must be under 0.25" WC.**

Any louver must meet these requirements, as exceeding these limits can cause the unit to overheat and fail and void the warranty.

The following louvers are approved for AIO Wall Mounted:

- Sunvent: LLA/C, LLA/M, LLA/S - available through your Ephoca distributor.
- Thermaduct: RLA6 - available through your Ephoca distributor.
- Primex: WCL8, WC6, WC8 - available online and in stores.
- Dundas Jaffine: IH6WXZ - available online and in stores.

# Exploded view

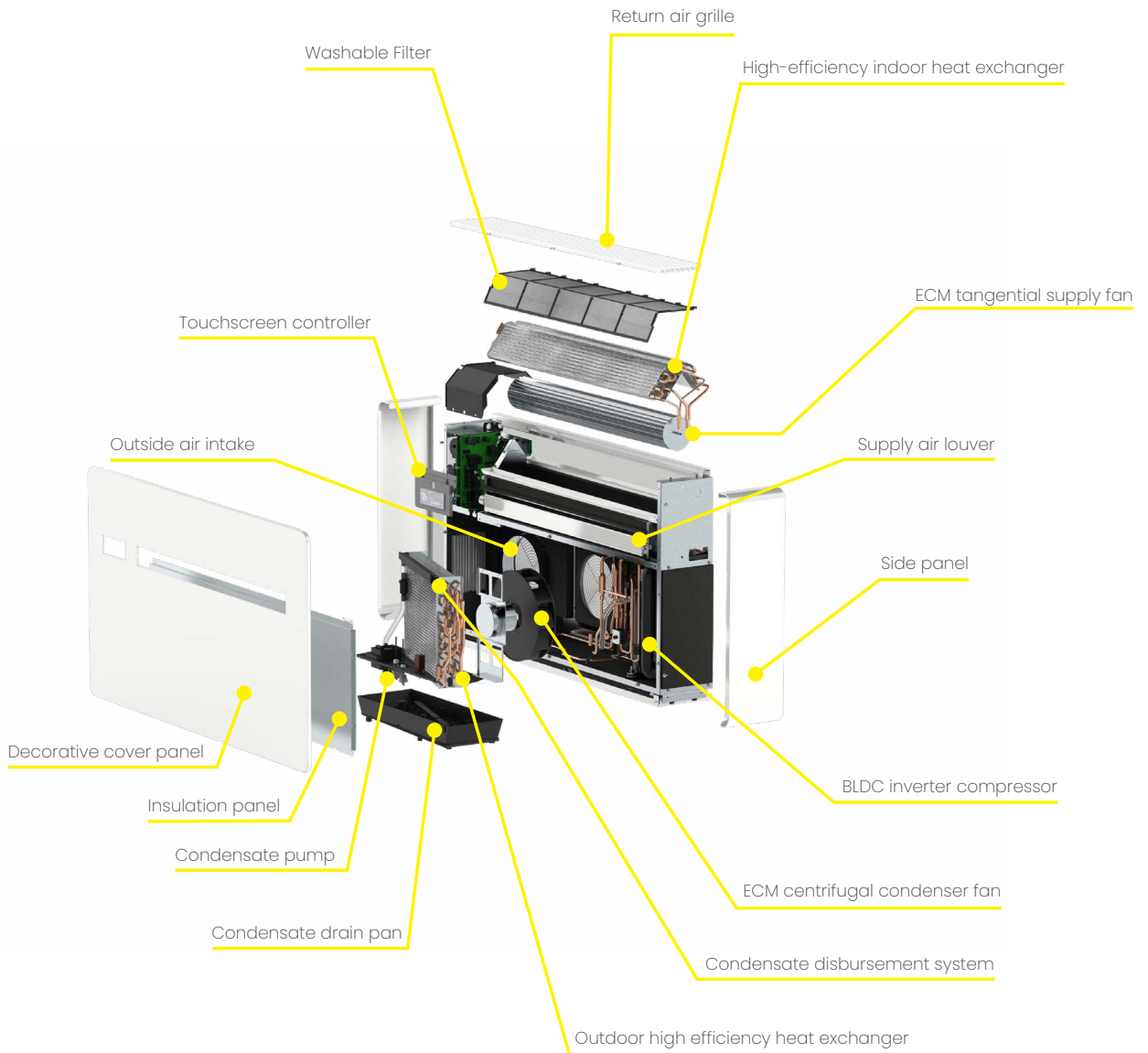

# Technical specifications

## Cooling

Indoor: 80°F, W.B. 67°F; Outdoor: 95°F, W.B. 75°F

Heat Pump		
Range	Btu/h	3,100 - 10,200
Nominal		8,000
Input Power	W	730
Efficiency	EER	10.96
	IEER	13.92

## Heating 47°

Indoor: 70°F, W.B. 60°F; Outdoor: 47°F, W.B. 43°F

Heat pump		
Range	Btu/h	3,500 - 10,100 + 6,100 Electric heat
Nominal		7,900 + 6,100 Electric heat
Input power	W	702
Efficiency	COP	3.30

## Heating 13°F

Indoor: 70°F, w.B. 60°F; Outdoor: 13°F, W.B. 9°F

Heat pump		
Range	Btu/h	6,100 - 5,200 + 6,100 Electric heat
Nominal		4,600 + 6,100 Electric heat
Input power	W	780
Efficiency	COP	1.73

## Heating 5°F

Indoor: 70°F W.B. 60°F; Outdoor : 5°F, W.B. 3°F

Heat pump		
Range	Btu/h	2,800 - 4,700 + 6,100 Electric heat
Nominal		4,300 + 6,100 Electric heat
Input power	W	790
Efficiency	COP	1.60

## Airflow

General		
Indoor	Type	ECM tangential
	CFM	160 - 290
	Speeds	Low, med, high, auto
	Filter	MERV 3
Outdoor	Type	ECM Centrifugal
	CFM	200 - 350
	Available ESP	0.25" WC
	Intake	
	Exhaust	6" round
	Speeds	Low, med, high, auto

## Sound

General		
Indoor	dB(A)	27 - 41
	STC	37
	OITC	28
Outdoor	dB(A)	28 - 52

## Compressor

230V

Model voltage		
Type		BLDC inverter
Refrigerant	Type	R410a
	Oz.	21.87
Oil	Type	Fv50s

## Electrical

230V

General		
Volt range		207 - 251
Hz/ phase		60 Hz single phase
Power supply		LCDI power cord NEMA 6 -15P
Power factor	%	0.96
Cooling (nominal)		3.3
Cooling (max)		4.8
Heating - heat pump (nominal)	A	3.2
Heating - heat pump + electric (max)		13
Input power (standby)		10.8
Input power (off mode)	W	1.7
MCA		14
MOCP	A	20

## General

Controls	
Basic functionality	Dependent on controller
Wi-Fi	Yes
ADA compliant	
Dry contact	Yes
Power outage restart	Auto-on based on last setting

Modes	
Operation	Cool, heat, dehumidify, auto
Restricted modes	Heat only, cool only, temperature limiting
Timers	Dependent on controller

Condensate	
Pipe size	3/4"

Physical data		
Dimensions	Net	39.7" W x 21.9" H x 6.5" D
	Gross	44" W x 26" H x 11" D
Weight	Net	91 Lb
	Gross	100 Lb
Cabinet	Finish	RAL 9003 signal white
	Material	Steel

Certification	
Safety	UL
Energy efficiency	BR Labs

Warranty	
Year 1	On-site parts and labor
Year 2 - 10	Parts only
	On-site parts and labor on compressor

# Airflow

In addition to the typical twin external vents, AIO Wall Mounted can attach to a sidewall adapter enabling mounting on a wall perpendicular to the outside.

## ■ Supply air

The supply air is through an electronically controlled louver that can be set at any angle or continuously oscillate.

## ■ Return air

The return air is on the top through the integrated return air grille.

## ■ Outside air intake

The 6-inch round outside air intake connection works with any of the approved or custom louvers/as long as they comply with the minimum requirements. See page 3.

## ■ Outside air exhaust

The 6-inch round outside air exhaust connection works with any of the approved or custom louvers/as long as they comply with the minimum requirements. See page 3.

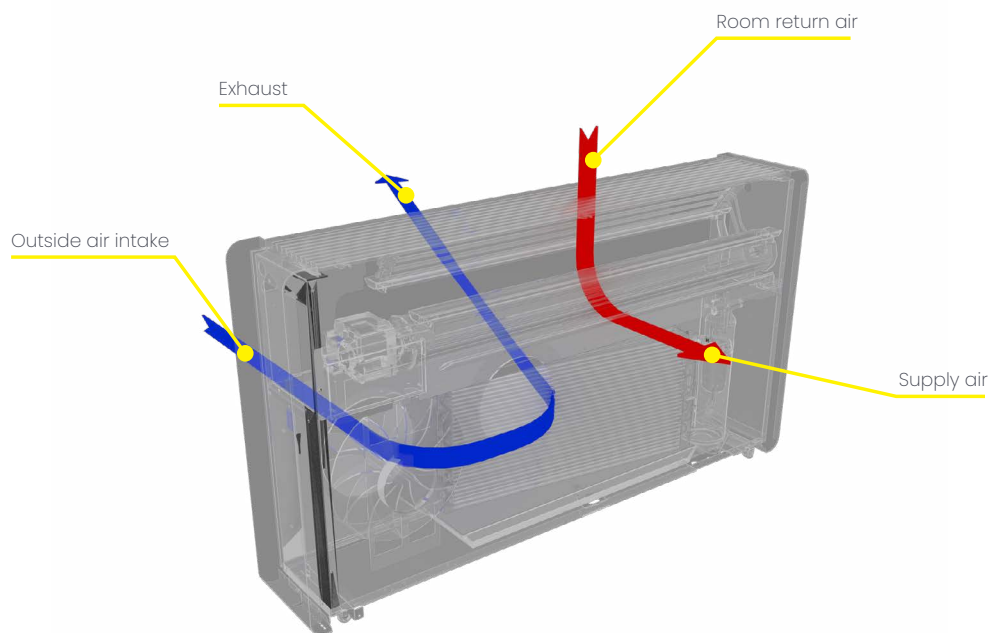

■ Outside air   ■ Recirculate air

# Testing procedure

AIO Wall Mounted's unique design does not fit any DOE or AHRI standards yet can be tested under AHRI 390 SPVU (Single Package Vertical Unit) or 210/240 Central Air Heat Pump for lack of better options.

However, both 210/240 and 390 are for ducted systems with medium or high static fans. AIO Wall Pro units are not designed to be ducted and use a low-pressure cross-flow blower fan, similar to the type of fan found in a PTAC.

Initially, we chose AHRI 210/240 as it offered a more comprehensive SEER, HSPF, and Energy Star ratings, while AHRI 390 only offered an EER and IEER and no Energy Star program.

During tests at Intertek, the technicians found a substantial loss of capacity and efficiency caused by ducting as required in 210/240 testing standard. This was verified by testing AIO under AHRI 380 as a PTAC where performance was substantially higher. However, AIO Wall Mounted can not be officially tested to AHRI 380, because it does not meet the definitions of a PTAC.

While AIO Wall Mounted's efficiency, when tested without ducting achieved over the required, the ducting brought the SEER below the required minimum. Therefore, we chose to test AIO Wall Mounted under AHRI 390, which only requires an EER of 11.0, which even with the ducting loss factor AIO Wall Mounted was able to meet and exceed.

From a legal and technical perspective, the only official ratings which can be published are ones tested to AHRI 390 by Intertek labs using ductwork. In real-life scenarios, where AIO Wall Mounted units are not ducted, the performance will be better than the official ratings.

## AIO is not a PTAC

10 CFR § 430.2 Definition of a PTAC

Packaged terminal heat pump means a packaged terminal air conditioner that utilizes reverse cycle refrigeration as its prime heat source and should have supplementary heating availability by builder's choice of energy.

Packaged terminal air conditioner means a wall sleeve and a separate unencased combination of heating and cooling assemblies specified by the builder and intended for mounting through the wall. It includes a prime source of refrigeration, separable outside louvers, forced ventilation, and heating availability energy.

AIO Wall Mounted can't be classified as a package terminal heat pump because:

- AIO Wall Mounted does not use a wall sleeve which the assembly sits inside.
- AIO Wall Mounted is a monoblock system that does not have a separate unencased combination of heating and cooling assemblies.
- AIO Wall Mounted mounts completely inside the room and is not intended or designed for mounting through a wall.

Therefore, AIO Wall Mounted can not be classified as a Packaged terminal air conditioner according to 10 CFR § 430.2.

## AIO is not a room air conditioner

10 CFR § 430.2 Definition of a room air conditioner

Room air conditioner means a consumer product, other than a "packaged terminal air conditioner," which is powered by a single-phase electric current and which is an encased assembly designed as a unit for mounting in a window or through the wall for the purpose of providing delivery of conditioned air to an enclosed space. It includes a prime source of refrigeration and may include a means for ventilating and heating.

AIO Wall Mounted can't be classified as a room air conditioner because:

- AIO Wall Mounted is clearly not "an encased assembly designed as a unit for mounting in a window or through the wall"

Therefore AIO Wall Mounted can not be classified as a room air conditioner according to 10 CFR § 430.2.



# AIO Wall Mounted AWK10N4L2 Submittal

Products are subject to continuous improvements and Ephoca reserves the right to modify product design, and specifications without notice.

Job	Reference	Construction
Location	Approval	Quote Number
Engineer	Date	Drawing Number
Submitted To	Submitted By:	P.O. Number:

## Cooling

Indoor: 80°F, W.B. 67°F; Outdoor: 95°F, W.B. 75°F

Heat Pump		
Range	Btu/h	3,100 - 10,200
Nominal		8,000
Input Power	W	730
Efficiency	EER	10.96
	IEER	13.92

## Heating 47°

Indoor: 70°F, W.B. 60°F; Outdoor: 47°F, W.B. 43°F

Heat pump		
Range	Btu/h	3,500 - 10,100 + 6,100 Electric heat
Nominal		7,900 + 6,100 Electric heat
Input power	W	702
Efficiency	COP	3.30

## Heating 13°F

Indoor: 70°F, w.B. 60°F; Outdoor: 13°F, W.B. 9°F

Heat pump		
Range	Btu/h	3,000 - 5,200 + 6,100 Electric heat
Nominal		4,600 + 6,100 Electric heat
Input power	W	780
Efficiency	COP	1.73

## Heating 5°F

Indoor: 70°F W.B. 60°F; Outdoor : 5°F, W.B. 3°F

Heat pump		
Range	Btu/h	2,800 - 4,700 + 6,100 Electric heat
Nominal		4,300 + 6,100 Electric heat
Input power	W	790
Efficiency	COP	1.60

## Airflow

General		
Indoor	Type	ECM tangential
	CFM	160 - 290
	Speeds	Low, med, high, auto
	Filter	MERV 3
Outdoor	Type	ECM Centrifugal
	CFM	200 - 350
	Available ESP	0.25"
	Intake	
	Exhaust	6" round
	Speeds	Low, med, high, auto

## Compressor

General		
Type		BLDC twin rotary inverter
Refrigerant		R410a

## Sound

General		
Indoor	dB(A)	27 - 41
	STC	37
	OITC	28
Outdoor	dB(A)	28 - 52

## Electrical

General		
Volt range		207 - 251
Hz/ phase		60 Hz single phase
Power Cord		LCDI power cord NEMA 6 -15P
Power factor	%	0.96
Cooling (nominal)		3.3
Cooling (max)		4.8
Heating (nominal)	A	3.2
Heating - heat pump + electric (max)		13

Circuit breakers		
MCA		14
Recommended breaker size	A	15
MOCP		20

## Warranty

Warranty		
Year 1		On-site parts and labor
Year 2 - 10		Parts only
		On-site parts and labor on compressor

## Dimensions

General		
Dimensions	Net	39.7" W x 21.9" H x 6.5" D
	Gross	44" W x 26" H x 11" D
Weight	Net	91 lb
	Gross	100 lb
Cabinet	Material	Steel
	Finish	RAL 9003 signal white

# Dimensions

## Dimensions

For CAD and DWG files, please scan or click the QR code below.

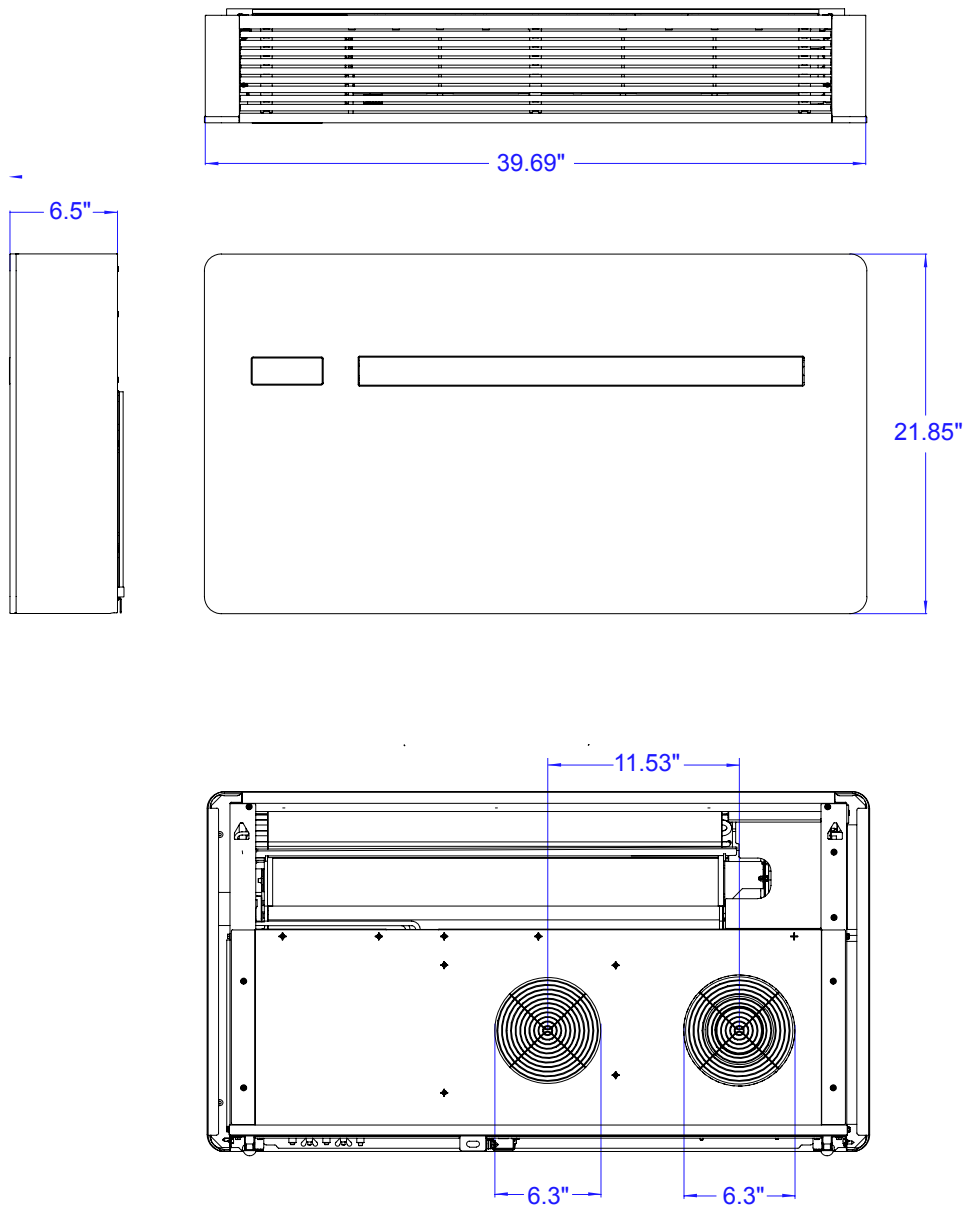

# Clearances

The AIO Wall mounted unit's clearance will depend on how it is mounted. Please carefully read the criteria below to determine the correct clearance required.

## ■ Top - low wall mounted

There must be 3.5" minimum clearance to any surface above, such as a shelf, etc. This is needed for the return airflow. 8" of clearance is recommended for ease in changing the filter and servicing the unit.

## ■ Top - high wall mounted

There must be 3.5" minimum clearance from the ceiling. This is needed for the return airflow. 8" of clearance is recommended for ease in changing the filter and servicing the unit.

## ■ Bottom

There must be a minimum of 1" from the floor to eliminate any noise from vibration. 2" of clearance is ideal to allow the floor under the unit to be cleaned.

## ■ Sides

The AIO Wall mounted unit should not touch the wall on either side as it will vibrate slightly during operation, which may create noise. As little as 1" clearance will suffice to eliminate any noise from vibration. A clearance of 2.5" on the sides allows for easier access when removing and installing the unit.

## ■ Front

Ensure no curtains, furniture, plants, or any material is within 30" in front of the unit. The supply air vent is on the front, and blocking it will inhibit the airflow and the unit from working correctly.

## ■ Rear

The rear of the unit must be tight to the wall so there are zero gaps between the wall and the unit. Gaps can allow outside air inside and create short cycling and humidity. If there are any gaps, they must be sealed with insulation.

## ■ Exterior

On the exterior of the building, there should be no obstacles blocking the airflow from the louver. There must be a least 36" of free and clear space in front of the louvers.

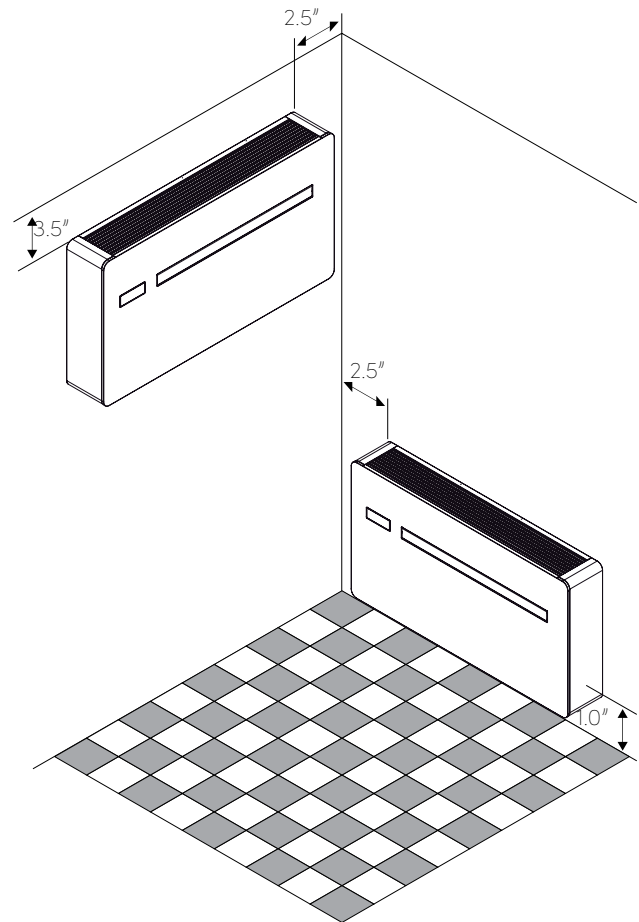

# Wiring diagram

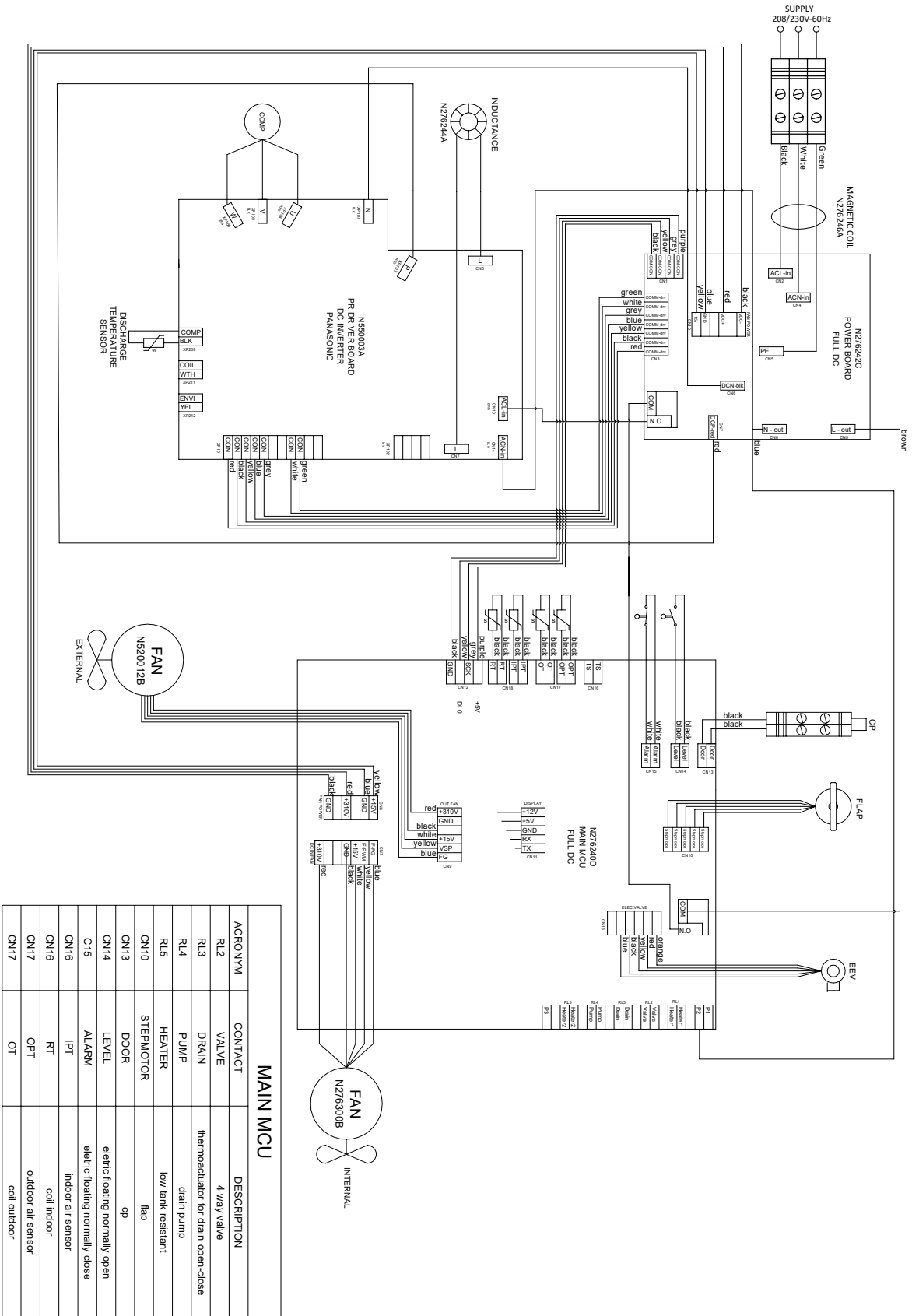

ACRONYM	CONTACT	DESCRIPTION
RL2	VALVE	4 way valve
RL3	DRAIN	thermoactuator for drain open-close
RL4	PUMP	drain pump
RL5	HEATER	low tank resistant
CN10	STEMOTOR	flap
CN13	DOOR	cp
CN14	LEVEL	electric floating normally open
C15	ALARM	electric floating normally close
CN16	IPT	indoor air sensor
CN16	RT	coil indoor
CN17	OPT	outdoor air sensor
CN17	OT	coil outdoor

# Mounting template

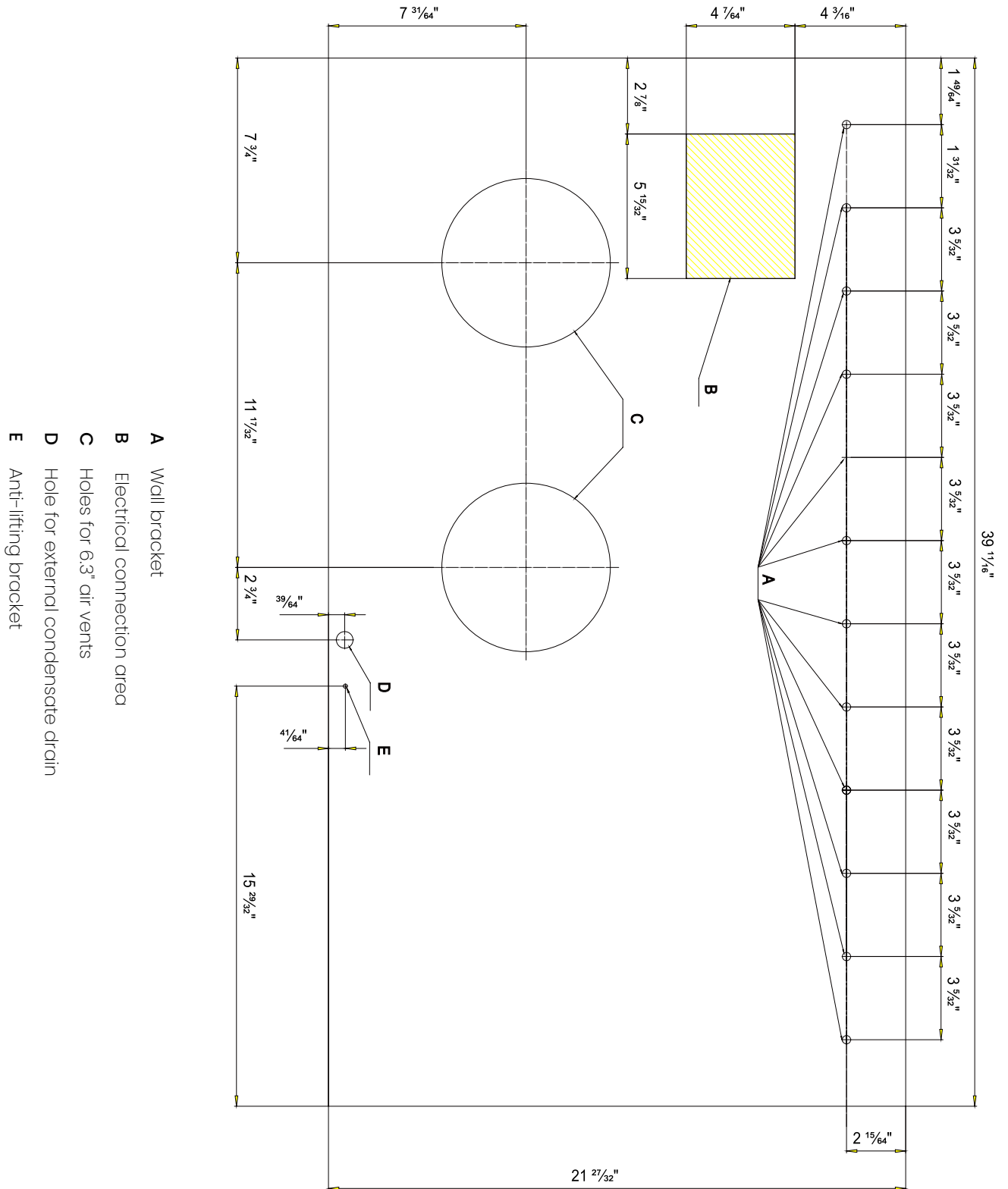



With over 15 years of experience in the climate comfort sector, we have a clear goal: growth through innovation. Our team is laser-focused on the conception, development, and production of innovative heating, ventilation, and air conditioning solutions. This mission has developed through bringing together technical skills, creativity, technology, design, Italian passion, and a global vision to achieve the best energy efficiency and performance.

Ephoca is the US subsidiary of Innova SRL - Via 1° Maggio, 8 - 38089 Storo (TN) Italy.

**ephoca.com** | 216-710-1000



**MADE IN ITALY**