



Product Data Sheet

Wall Mounted AWE10R4L2

List: \$6,936

- Integrated ERV
- 900W electric heat
- R410a
- LCDI power cord
- 230V



SAFETY WARNING

Only qualified professionals should install and service this equipment. Improperly installed or modifications by an unqualified person could result in death or serious injury. When working on the equipment, observe all precautions in the installation manual and labels attached to the equipment.



Contents

Key features	3	Clearances	14
Technical requirements	4	Wiring diagram	15
AIO wall mounted pro specifications	4	Mounting template	16
Louver specifications	4		
What's inside	5		
Technical specifications	6		
Airflow	8		
Understanding the ratings	9		
How AIO works	9		
Explanation of the terms	9		
Heat Pump	9		
Testing procedure	11		
AIO is not a PTAC	11		
AIO is not a room air conditioner	11		
AWE10R4L2 Submittal	12		
Dimensions	13		

AIO Wall Mounted units are slim and sleek. The wall-mounted unit can be mounted high or low with a factory-supplied bracket, making installation quick and simple. An electronically controlled louver with an auto-swing function distributes airflow comfortably and uniformly. The ERV enables controlled and treated fresh air intake and stale air exhaust. Wall-mounted units are ideal for any area with free wall space. The onboard touch controller simplifies use and installation. A special adapter enables the unit to be installed perpendicular to an outside wall.

Ephoca is constantly innovating and improving its products and reserves the right to modify product design and specifications without notice and without incurring any obligations.

Ephoca is the US subsidiary of Innova SRL - Via 1° Maggio, 8 - 38089 Storo (TN) Italy.

© 2023 Ephoca. All rights reserved.

Key Features

■ No outdoor unit

The single package design means no outdoor unit, freeing up space on rooftops and at ground level and enabling installations in buildings without space for an outdoor unit.

■ BLDC inverter compressor

The state-of-the-art BLDC inverter compressor operates efficiently, quietly, and with minimal vibration. AIO is ideal for any room or area that requires between 4,000 and 9,000 BTU.

■ Integrated ERV

AIO's integrated ERV eliminates the requirement of installing an independent ERV system, ducting, electrical work, and engineering.

■ Recovery plus™

With a patent pending innovation, AIO utilizes the heat or cold remaining in the air after passing through the recovery core to lower or raise the temperature of the condenser, enabling a boost in performance and efficiency.

■ MERV 13 clean air

Clean outdoor air is essential to well-being and safety. The MERV 13 filter ensures that all air entering the room/home is clean and safe. Additionally, stale air is passed through a second MERV 13 filter keeping the core clean.

■ High-efficiency ECM fans with auto ESP

High-efficiency ECM fans enable efficient and quiet operation as the EC motor can ramp up or down depending on the need. Automatically adjusted external static pressure ensures correct airflow.

■ Cold climate heat pump

The heat pump with efficiently function down to 5°F outdoors.

■ 900 Watt electric heat

The electric heat works in conjunction with the heat pump when the heat pump has insufficient power.

■ Intelligent defrosting

AIO's intelligent defrosting system means more time heating and less time on reverse cycle defrost.

■ Coil cooling system

The condensate mister system drizzles the condensate on the outdoor heat exchanger coils, lowering the coil's temperature and increasing efficiency and performance.

■ Quiet

With whisper-quiet operation as low as 27 decibels, the occupant will barely notice AIO is operating.

■ No outside noise infiltration

AIO has the lowest STC and OITC rating among comparable units. This means less outside noise intruding into the room day and night.

■ Versatile on/off options

AIO's low voltage connection enables connection to any occupancy system, key-card, window sensors, fire alarms, etc.; as long as it can send a signal to AIO via low voltage, the unit can be easily turned on or off.

■ Corrosion protection

AIO comes standard with corrosion protection, assuring many years of trouble-free performance.

■ Minimal clearances and compact footprint

AIO's compact form with no line sets means there is no need to access the sides of the unit. Mount units with as little as 3/4 inch clearance on all sides. Compact footprints take up minimum space.

■ Leak protection

A drain alarm will activate if the drain becomes clogged, and the system will be shut off, preventing water damage.

■ Easy to service

AIO can be easily maintained and repaired from the front or bottom of the unit without having to remove the unit from the wall or ceiling. AIO can also be quickly swapped out with a replacement, reducing downtime.

■ Versatile controls

AIO includes an iOS and android app and an onboard touch controller. AIO can be used with optional wall-mounted controllers, including a TFT with 7 day program and third-party controllers from any company using the optional 3rd party kit. An optional BACnet and Modbus module enables interfacing with building management systems

■ 10-Year limited warranty

An industry-leading ten-year limited on-site warranty provides peace of mind. One full-year parts and labor. Nine-year parts and a full ten-year parts and labor on the sealed system, including the compressor.

Technical requirements

AIO wall mounted specifications

Note: Refer to the full specifications for detailed information about the list of specifications.

- An electrical supply with a grounded 3-prong receptacle.
- The power supply circuit is installed in accordance with the current edition of NEC (ANSI/NFPA 70) and local codes and ordinances. Note: Always consult local and national electric codes.
- Voltage rating of 60 Hz, 208-230V single phase.
- Interior clearances as follows:
 - Sides of unit to wall: 1"
 - Bottom of unit to floor 1"
 - Top of unit to any obstruction: 3.5"
- Unblocked vents on the exterior and no obstacles within 36".
- Properly installed insulated condensate drain line with a minimum of 30% slope if an external drain. If using an external drain on a low floor, ensure that end of drain is above the maximum height of snow buildup. An internal drain is highly recommended.
- Approved louvers installed with best practices to ensure no water into the wall assembly.
- 6" or larger diameter ducts through the wall which protrude 1/8" into the unit's EPDM backing to ensure a tight seal.
- The unit must be perfectly level on the vertical and horizontal axis.
- The unit must be tight to the wall, with zero leakage between the external ducts and the unit. Use insulating material if wall is not level.
- Properly affixed wall bracket to wall studs or other supporting material.

Louver specifications

AIO Wall Mounted units can be vented through all kinds of custom and creative solutions. The possibilities are endless, from perforated panels to custom louvers.

There are two critical factors in selecting and sizing a solution that will work with AIO Wall Mounted units.

- **Free area:** This area on a louver/grille is open for the air to flow through. The louver, perforated panel, or other solution must have at least the amount of free area as required in the specifications below in the plenum from the unit so that ample air can enter and exit the condenser chamber. A more restrictive solution with a smaller free area can be utilized by enlarging the louver and plenum until the required free area is achieved.

The minimum free area required is .21 sq feet for the intake vent and .21 sq feet for the exhaust vent.

- **Pressure drop:** Pressure drop is the resistance the louver/grille creates against the airflow. This resistance can create heat build-up inside the condenser portion, causing the compressor to overheat and shut down. A solution with a higher pressure drop than specified can be utilized by enlarging the louver and plenum until the pressure drop is within specification.

The maximum total pressure for the intake and exhaust louvers combined must be under 0.25" WC.

Any louver must meet these requirements, as exceeding these limits can cause the unit to overheat and fail and void the warranty.

The following louvers are approved for AIO Wall Mounted:

- Sunvent: LLA/C, LLA/M, LLA/S - available through your Ephoca distributor.
- Therma duct: RLA6 - available through your Ephoca distributor.
- Primex: WCL8, WC6, WC8 - available online and in stores.
- Dundas Jaffine: IH6WXZ - available online and in stores.

What's inside

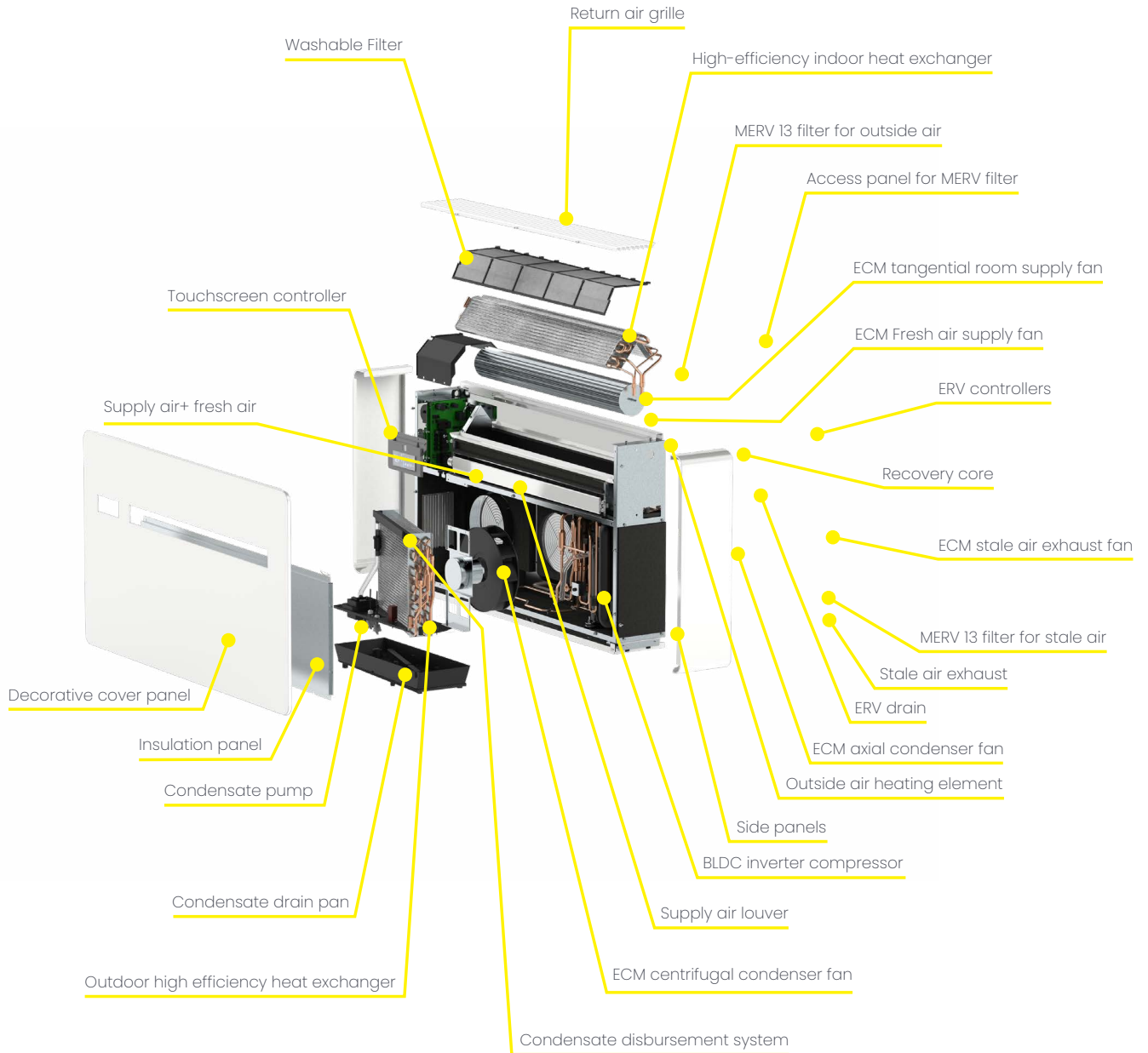

Technical specifications

Cooling

Indoor: 80°F, W.B. 67°F; Outdoor: 95°F, W.B. 75°F

		15 CFM	25 CFM	40 CFM
Heat Pump				
Range	Btu/h	3,100 - 10,200		
Nominal		8,000		
Input Power	W	730		
Efficiency	EER	10.96		
	IEER	13.92		
ERV				
Sensible recovery	Btu/h	220	350	500
Latent recovery		150	250	330
Input Power	W	8	15	30
Efficiency	EER	16.12	13.68	9.77
Combined Heat Pump + ERV'				
Range	Btu/h	3,870 - 10,470	4,100 - 10,700	4,330 - 10,930
Nominal		8,370	8,600	8,830
Input Power	W	738	745	760
Efficiency	EER	11.34	11.54	11.62
Moisture Removal	Pts/h	1.9		

Heating 47°

Indoor: 70°F, W.B. 60°F; Outdoor: 47°F, W.B. 43°F

		15 CFM	25 CFM	40 CFM
Heat pump				
Range	Btu/h	3,500 - 10,100		
Nominal		7,900		
Input power	W	702		
Efficiency	COP	3.30		
ERV				
Recovery	Btu/h	350	550	800
Input power	W	8	15	30
Efficiency	COP	12.82	10.75	7.82
Combined heat pump +ERV'				
Range	Btu/h	3,850 - 10,450	4,050 - 10,650	4,300 - 10,900
		+ 3,000 Electric heat		
Nominal	Btu/h	8,200	8,500	8,700
		+ 3,000 Electric heat		
Input power	W	710	717	732
Efficiency	COP	3.38	3.47	3.48

Heating 13°F

Indoor: 70°F, W.B. 60°F; Outdoor: 13°F, W.B. 9°F

		15 CFM	25 CFM	40 CFM
Heat pump				
Range	Btu/h	3,000 - 5,200		
Nominal		4,600		
Input power	W	780		
Efficiency	COP	1.73		
ERV				
Recovery	Btu/h	930	1,480	2,150
Input power	W	8	15	30
Efficiency	COP	34.07	28.92	21.00

Heating 13°F (continued)

Indoor: 70°F, W.B. 60°F; Outdoor: 13°F, W.B. 9°F

		15 CFM	25 CFM	40 CFM
Combined heat pump + ERV'				
Range	Btu/h	3,930 - 6,130	4,480 - 6,680	5,150 - 7,350
		+ 3,000 Electric heat		
Nominal	Btu/h	5,530	6,080	6,750
		+ 3,000 Electric heat		
Input power	W	788	795	810
Efficiency	COP	2.76	3.01	3.28

Heating 5°F

Indoor: 70°F, W.B. 60°F; Outdoor: 5°F, W.B. 3°F

		15 CFM	25 CFM	40 CFM
Heat pump				
Range	Btu/h	2,800 - 4,700		
Nominal		4,300		
Input power	W	790		
Efficiency	COP	1.60		
ERV				
Recovery	Btu/h	1,060	1,680	2,400
Input power	W	8	15	30
Efficiency	COP	38.83	32.83	23.45
Combined heat pump + ERV'				
Range	Btu/h	3,860 - 5,760	4,480 - 6,380	5,200 - 7,100
		+ 3,000 Electric heat		
Nominal	Btu/h	5,360	5,980	6,700
		+ 3,000 Electric heat		
Input power	W	798	805	820
Efficiency	COP	1.97	2.18	2.39

ERV

General	
Flow type	Counterflow enthalpy exchanger
Material	Mold and bacteria resistant, washable polymer membrane
ASHRAE compliance	62.1 And 62.2 When used with the ERV module

		15 CFM	25 CFM	40 CFM
Efficiency of core in winter				
Sensible	%	81.4	77.5	72.8
Latent		68.5	62.3	56.4
Efficiency of core in summer				
Sensible	%	70.2	65.1	58.2
Latent		52.4	53.5	54.7
Filter				
Indoor air		MERV 3 / optional MERV 13		
Outside air	MERV	MERV 13		
Leakage				
Internal	WC	2.6% at 0.40"	2.4% at 0.40"	2.2% at 0.40"
External		2.8% at 1.0"	2.7% at 1.0"	2.5% at 1.0"

To understand the ratings, please see the section "Understanding the ratings" on the following pages.

Technical specifications

Airflow

Fresh air volume		
Indoor	Type	ECM tangential
	CFM	160 - 290
	Speeds	Low, med, high, auto
	Filter	MERV 3
Fresh air intake	Type	ECM centrifugal
	CFM	15 - 40
	Speeds	Based on CFM
	Filter	MERV 13
Stale air exhaust	Type	ECM centrifugal
	CFM	15 - 40
	Speeds	Based on CFM
	Filter	MERV 13
Outdoor	Type	ECM Centrifugal
	CFM	200 - 350
	Available ESP	0.25" WC
	Intake connection	6" round
	Exhaust connection	
	Speeds	Low, med, high, auto

Electrical

230V		
General		
Volt range		207 - 251
Hz/ phase		60 Hz single phase
Power supply		LCDI power cord NEMA 6-15P
Power factor	%	0.96
Cooling (nominal)		3.0
Cooling (max)		4.8
Heating - heat pump only (nominal)	A	3.1
Heating - heat pump + electric (max)		9.1
Input power (standby)		10.8
Input power (off mode)	W	1.7
Motors		
Compressor	RLA	2.8
	LRA	3.9
	W (max)	50
Indoor ECM fan motor	F.L.A.	0.2
	HP	0.07
	W (max)	30
Fresh air intake ECM fan motor	F.L.A.	0.3
	HP	0.04
	W (max)	30
Stale air exhaust ECM fan motor	F.L.A.	0.1
	HP	0.04
	W (max)	90
Outdoor ECM fan motor	F.L.A.	0.4
	HP	0.12

Circuit Breakers

Circuit breakers		
MCA - heat pump only		10
Recommended breaker size	A	15
MOCP		15

Compressor

230V		
Model voltage		
Type		BLDC inverter
Refrigerant	Type	R410a
	Oz.	21.87
Oil	Type	Fv50s

Sound

General		
Indoor	dB(A)	27 - 41
	STC	37
	OITC	28
Outdoor	dB(A)	28 - 52

General

Controls	
Basic functionality	Dependent on controller
Wi-Fi	Yes
ADA compliant	
Dry contact	Yes
Power outage restart	Auto-on based on last setting

Modes	
Operation	Cool+ fresh air, cool only, heat+ fresh air, heat only, auto
Restricted modes	Heat only, cool only, temperature limiting
Timers	Dependent on controller

Condensate		
Pipe size	Size	3/4" Outside diameter
	Material	Rubber

Physical data		
Dimensions	Net	39.7" W x 21.9" H x 11.5" D
	Gross	44" W x 26" H x 15" D
Weight	Net	130 lb
	Gross	135 lb
Cabinet	Material	Steel
	Finish	RAL 9003 signal white

Certification	
Safety	UL
Energy efficiency	BR Labs

Warranty	
Year 1	On-site parts and labor
Year 2 - 10	Parts only
	On-site parts and labor on compressor

Airflow

In addition to the typical twin external vents, AIO Wall Mounted can attach to a sidewall adapter enabling mounting on a wall perpendicular to the outside.

■ Supply air

The supply air is through an electronically controlled louver that can be set at any angle or continuously oscillate.

■ Return air

The return air is on the top through the integrated return air grille.

■ Outside air intake

The 6-inch round outside air intake connection works with any of the approved or custom louvers/as long as they comply with the minimum requirements. See page 3.

■ Outside air exhaust

The 6-inch round outside air exhaust connection works with any of the approved or custom louvers/as long as they comply with the minimum requirements. See page 3.

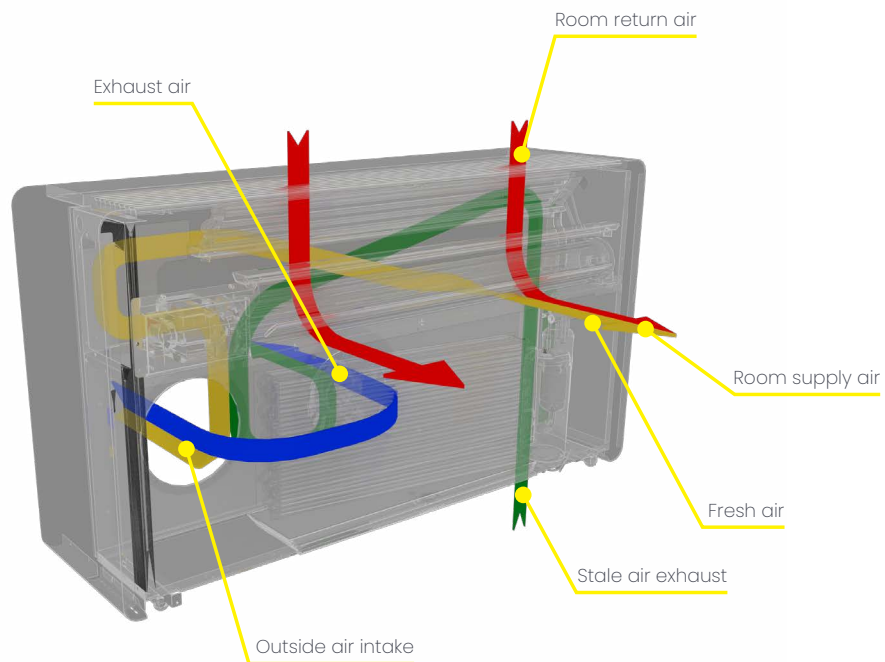

■ Outside air ■ Recirculate air ■ Fresh air intake ■ Stale air exhaust

Understanding the ratings

AIO is a unique system that incorporates a heat pump and ERV in a single package. To understand the specifications, you must read this first to understand. There are different ways to bring treated outside air into a dwelling unit; using a rooftop package, PTAC or VTAC, DOAS, ERV, or a fresh air intake kit.

■ Package systems such as Rooftop, PTAC, and VTAC

In these systems, outside air is introduced via a vent and heated/cooled using the heat pump or electric heat (if the outside temperature is below the heat pump's operating range). The heat pump's capacity must include inside and outside air loads.

■ DOAS (Dedicated Outside Air Systems)

DOAS units condition the outside air to inside temperature with a heat pump. With a DOAS, the only load is the outside air.

■ ERV Systems

ERV systems utilize the heat/cold from the exhausted stale air to heat/cool the incoming outside air. As ERVs are only 60% and 85% efficient, the outside air must be further heated/cooled to meet room temperature. Depending on the system design, the air can be passed through an additional dedicated heat pump or passed into the return of a fan coil unit. Regardless, the heat pump's capacity must be calculated to cover the load which the ERV does not recover.

■ Fresh air intake kit for indoor units

Some indoor units (such as cassettes and ducted) of VRF and other split systems will accommodate a fresh air kit, where outside air is ducted into the return of the indoor units. The indoor fan coil and connected outdoor heat pump must accommodate inside and outside air loads.

How AIO works

AIO integrates an ERV with the heat pump providing an all-in-one solution with maximum efficiency. Outside air is initially treated by the super-efficient ERV core, recovering up to 86% of the sensible heat from the exhaust air, and the heat pump treats the remainder before it enters the supply air. To further boost efficiency, the heat remaining after passing through the recovery core is used to slightly warm/cool the outdoor heat exchanger, lowering/raising the coil's temperature.

With AIO, just like any other solution with an ERV, a percentage of the heat pump's capacity is used to heat the outside air and must be factored into the load calculation. AIO is available with or without the ERV option; if AIO is used only as a heat pump, all the heat pump's capacity can be utilized for the room's load.

 ephoca AIO Wall Mounted Product Data Sheet AWEI0R4L2

Explanation of the terms

Below is a list of terms used in the specifications and their explanation.

Heat Pump

■ Range

AIO's twin rotary inverter compressor enables a wide range of capacities. The capacity range reflects the minimum and maximum capacity of the heat pump. Using AIO in an environment that requires less than the minimum will result in AIO's inverter compressor operating as an on-off compressor. While this will not damage AIO or shorten the lifespan, it will reduce efficiency. It is important to note that a small percentage of the capacity will be utilized to heat/cool the outside air.

While the capacity range is wide, Ephoca does not recommend using AIO in an environment that consistently requires more than 11,000 BTU. Beyond that limit, AIO is louder and less efficient. The additional capacity is helpful for those occasions when extra capacity is needed.

■ Nominal

This is rated capacity, used for efficiency testing purposes. With an inverter-based heat pump, a manufacturer can "lock" the inverter compressor to a specific frequency to control the capacity for a test. This capacity was selected as it achieves the optimum efficiency to capacity ratio. A lower capacity will achieve a more efficient rating but will be officially too small, and a larger capacity will have a less efficient rating with inverter compressors; the lower the frequency (capacity), the better the efficiency. This is what makes inverters so efficient, as most of the time, an inverter will operate at less than half the capacity. This number rating is only provided for official rating purposes and for comparing with similar units in apples-to-apples comparisons.

■ Input power

This is the input power to operate AIO at the rated capacity and does not include the input power of the ERV fans. Using AIO in an environment that requires less capacity than the rated will result in less power input, and a higher capacity will use more input power.

■ Efficiency

This is the official efficiency of AIO based on AHRI testing standards based on the rated capacity. Using AIO in an environment that requires less than the rated will result in a higher efficiency rating. An environment with higher loads will have a lower efficiency rating. This number is only provided for official rating purposes and to compare with similar units in apples-to-apples comparisons.

Understanding the ratings

ERV

■ Capacity

This is the capacity of the ERV based on CFM of outside air. The higher the CFM, the higher the capacity. It is critical to note that the ERV's capacity can only be used to offset the load required to heat/cool the outside air, which will always be greater than the capacity of the ERV. This capacity never be used to heat/cool the inside air.

■ Input power

This is the input power of two ERV fans. One pulls outside air through the ERV core; the other pulls the stale air through the ERV core. The higher the CFM of outside air, the higher the input power. The CFM of outside air is fully controllable and can be set anywhere from 10 to 90 CFM. The speed of the ECM fans controls this.

■ Efficiency

The effective efficiency of the ERV is exceptionally high, as the only input power is the ECM fan. The efficiency is dependent upon the CFM and related fan power.

■ Nominal

This capacity range is useful as a quick reference to see if AIO will be able to support the combined load of indoor and outside air. This combined capacity can not be used solely for inside air.

■ Input power

This is the input power to operate AIO at the rated capacity and the input power of the ERV fans. Using AIO in an environment that requires less capacity than the rated will result in less power input and a higher capacity will use more input power.

■ Efficiency

The effective efficiency of the heat pump and the ERV is higher than the efficiency of just the heat pump. However, this combined efficiency presents a more accurate picture of the efficiency of AIO as it shows the benefit of a combined ERV heat pump versus other types of configurations.

Combined Heat Pump + ERV Section

■ Range

This reflects the combined capacity range of the heat pump (as described in the heat pump section) and the ERV (as described in the ERV section). This combined capacity range helps compare the capacity required using only a heat pump to heat/cool the outside and inside air instead of an ERV and a heat pump.

For example, a 12x15 room requires 8,000 BTU, and 35 CFM of outside air requires 3,000 BTU, requiring 11,000 BTU's.

There are two ways to achieve this:

- Typical, where all 11,000 BTU are from the heat pump/ electric heat.
- AIO, with 11,000 BTU of combined capacity. In this case, AIO's heat pump provides 8,000 BTUs for the room and 480 BTU (16% of the 3,000 BTU) for the outside air. The recovery on the ERV would provide the remaining 2,520 BTU required to heat/cool the outside air.

This capacity range is useful as a quick reference to see if AIO will be able to support the combined load of indoor and outside air. This combined capacity can not be used solely for inside air.

Testing procedure

AIO Wall Mounted's unique design does not fit any DOE or AHRI standards yet can be tested under AHRI 390 SPVU (Single Package Vertical Unit) or 210/240 Central Air Heat Pump for lack of better options.

However, both 210/240 and 390 are for ducted systems with medium or high static fans. AIO Wall Pro units are not designed to be ducted and use a low-pressure cross-flow blower fan, similar to the type of fan found in a PTAC.

Initially, we chose AHRI 210/240 as it offered a more comprehensive SEER, HSPF, and Energy Star ratings, while AHRI 390 only offered an EER and IEER and no Energy Star program.

During tests at Intertek, the technicians found a substantial loss of Nominal and efficiency caused by ducting as required in 210/240 testing standard. This was verified by testing AIO under AHRI 380 as a PTAC where performance was substantially higher. However, AIO Wall Mounted can not be officially tested to AHRI 380, because it does not meet the definitions of a PTAC.

While AIO Wall Mounted's efficiency, when tested without ducting achieved over 16 SEER, the ducting brought the SEER below the required minimum. Therefore, we chose to test AIO Wall Mounted under AHRI 390, which only requires an EER of 11.0, which even with the ducting loss factor AIO Wall Mounted was able to meet and exceed.

From a legal and technical perspective, the only official ratings which can be published are ones tested to AHRI 390 by Intertek labs using ductwork. In real-life scenarios, where AIO Wall Mounted units are not ducted, the performance will be better than the official ratings.

AIO is not a PTAC

10 CFR § 430.2 Definition of a PTAC

Packaged terminal heat pump means a packaged terminal air conditioner that utilizes reverse cycle refrigeration as its prime heat source and should have supplementary heating availability by builder's choice of energy.

Packaged terminal air conditioner means a wall sleeve and a separate unencased combination of heating and cooling assemblies specified by the builder and intended for mounting through the wall. It includes a prime source of refrigeration, separable outside louvers, forced ventilation, and heating availability energy.

AIO Wall Mounted can't be classified as a package terminal heat pump because:

- AIO Wall Mounted does not use a wall sleeve which the assembly sits inside.
- AIO Wall Mounted is a monoblock system that does not have a separate unencased combination of heating and cooling assemblies.
- AIO Wall Mounted mounts completely inside the room and is not intended or designed for mounting through a wall.

Therefore, AIO Wall Mounted can not be classified as a Packaged terminal air conditioner according to 10 CFR § 430.2.

AIO is not a room air conditioner

10 CFR § 430.2 Definition of a room air conditioner

Room air conditioner means a consumer product, other than a "packaged terminal air conditioner," which is powered by a single-phase electric current and which is an encased assembly designed as a unit for mounting in a window or through the wall for the purpose of providing delivery of conditioned air to an enclosed space. It includes a prime source of refrigeration and may include a means for ventilating and heating.

AIO Wall Mounted can't be classified as a room air conditioner because:

- AIO Wall Mounted is clearly not "an encased assembly designed as a unit for mounting in a window or through the wall"

Therefore AIO Wall Mounted can not be classified as a room air conditioner according to 10 CFR § 430.2.

AIO Wall Mounted AWE10R4L2 Submittal

Products are subject to continuous improvements and Ephoca reserves the right to modify product design, and specifications without notice.

Job	Reference	Construction
Location	Approval	Quote Number
Engineer	Date	Drawing Number
Submitted To	Submitted By:	P.O. Number:

ERV performance

General	
Flow type	Counterflow enthalpy exchanger
Material	Mold and bacteria resistant, washable polymer membrane
ASHRAE compliance	62.1 And 62.2 When used with the ERV module

	15 CFM	25 CFM	40 CFM
Efficiency of core in winter			
Sensible Btu/h	81.4	77.5	72.8
Latent	68.5	62.3	56.4

Efficiency of core in summer			
Sensible %	70.2	65.1	58.2
Latent	52.4	53.5	54.7

Filter	
Indoor air	MERV 3 / optional MERV 13
Outside air	MERV 13

Leakage	
Internal	2.6% at 0.40"
External	2.8% at 1.0"

Heat pump performance

Cooling	
Moisture Removal	Pts/h 1.9
Range	Btu/h 3,100 - 10,200
Nominal	Btu/h 8,000
Input Power	W 730
Efficiency	EER 10.96
	IEER 13.92

Heating	
Sensible Heat Factor	% 86
Range	Btu/h 3,500 - 10,100 + 3,000 electric heat
Nominal	Btu/h 7,900 + 3,000 electric heat
Input Power	W 702
Efficiency	COP 3.30

Range	Btu/h 3,000 - 5,200 + 3,000 electric heat
Nominal	Btu/h 4,600 + 3,000 electric heat
Input Power	W 780
Efficiency	COP 1.73

Range	Btu/h 2,800 - 4,700 + 3,000 electric heat
Nominal	Btu/h 4,300 + 3,000 electric heat
Input Power	W 790
Efficiency	COP 1.60

Compressor

General	
Type	BLDC inverter
Refrigerant	Type R410a

Airflow

General		Indoor	Fresh air	Outdoor
Fan	Motor		ECM	
Type	Tangential	Centrifugal	Centrifugal	Centrifugal
Input power	W 50	30+30	90	
Airflow	CFM 160 - 290	15 - 40	200 - 350	
ESP	WC N/A	N/A	0.25"	
Speeds	Low, med, high, auto	Auto	Low, med, high, auto	

Sound

General	
Indoor	dB(A) 27 - 41
	STC 37
	OITC 28
Outdoor	dB(A) 28 - 52

Electrical

General	
Volt range	207 - 251
Hz/ phase	60 Hz single phase
Power Cord	Hardwire
Power factor	% 0.96
Cooling (nominal)	3.0
Cooling (max)	4.8
Heating (nominal)	A 3.1
Heating - heat pump + electric (max)	9.1

Circuit breakers	
MCA - heat pump only	10
Recommended breaker size	A 15
MOCP	15

Warranty

Warranty	
Year 1	On-site parts and labor
Year 2 - 10	Parts only
	On-site parts and labor on compressor

Dimensions

General	
Dimensions	Net 39.7" W x 21.9" H x 11.5" D
	Gross 44" W x 26" H x 15" D
Weight	Net 130 lb
	Gross 135 lb
Cabinet	Material Steel
	Finish RAL 9003 signal white

Dimensions

Dimensions

For CAD and DWG files, please scan or click the QR code below.

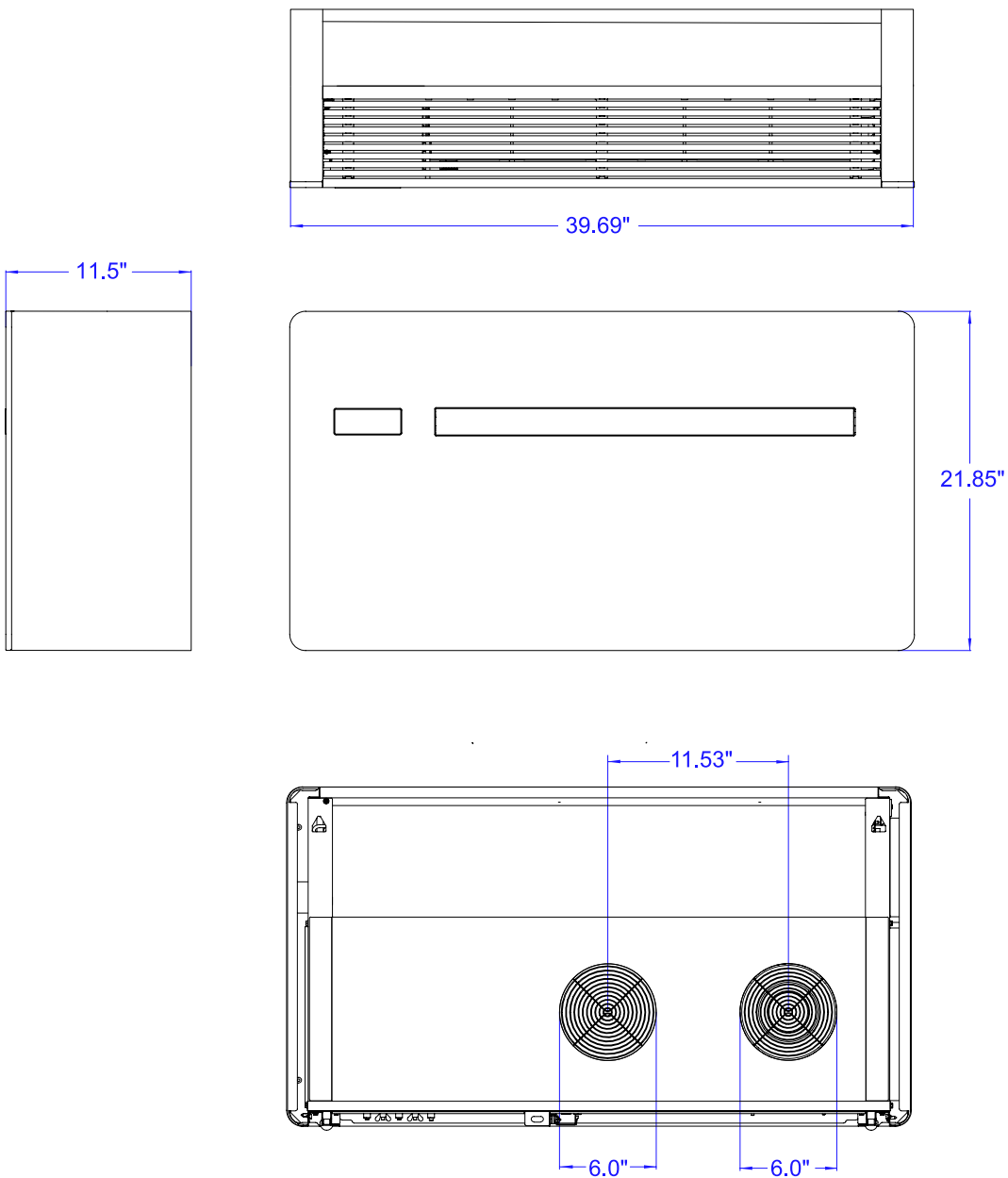

Clearances

The AIO Wall mounted unit's clearance will depend on how it is mounted. Please carefully read the criteria below to determine the correct clearance required.

■ Top - low wall mounted

There must be 3.5" minimum clearance to any surface above, such as a shelf, etc. This is needed for the return airflow. 8" of clearance is recommended for ease in changing the filter and servicing the unit.

■ Top - high wall mounted

There must be 3.5" minimum clearance from the ceiling. This is needed for the return airflow. 8" of clearance is recommended for ease in changing the filter and servicing the unit.

■ Bottom

There must be a minimum of 1" from the floor to eliminate any noise from vibration. 2" of clearance of is ideal to allow the floor under the unit to be cleaned.

■ Sides

The AIO Wall mounted unit should not touch the wall on either side as it will vibrate slightly during operation, which may create noise. As little as 1" clearance will suffice to eliminate any noise from vibration. A clearance of 2.5" on the sides allows for easier access when removing and installing the unit.

■ Front

Ensure no curtains, furniture, plants, or any material is within 30" in front of the unit. The supply air vent is on the front, and blocking it will inhibit the airflow and the unit from working correctly.

■ Rear

The rear of the unit must be tight to the wall so there are zero gaps between the wall and the unit. Gaps can allow outside air inside and create short cycling and humidity. If there are any gaps, they must be sealed with insulation.

■ Exterior

On the exterior of the building, there should be no obstacles blocking the airflow from the louver. There must be a least 36" of free and clear space in front of the louvers.

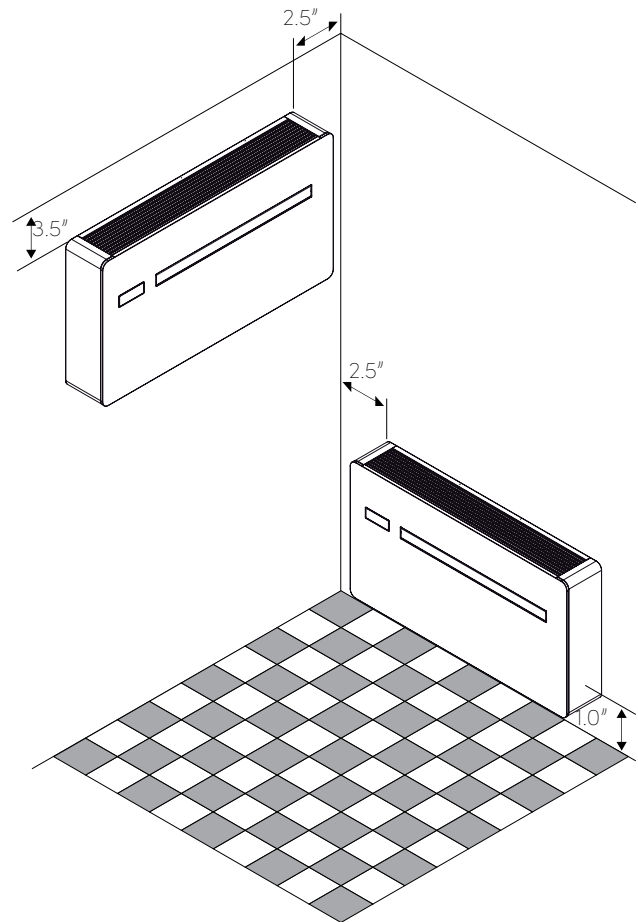

Wiring diagram

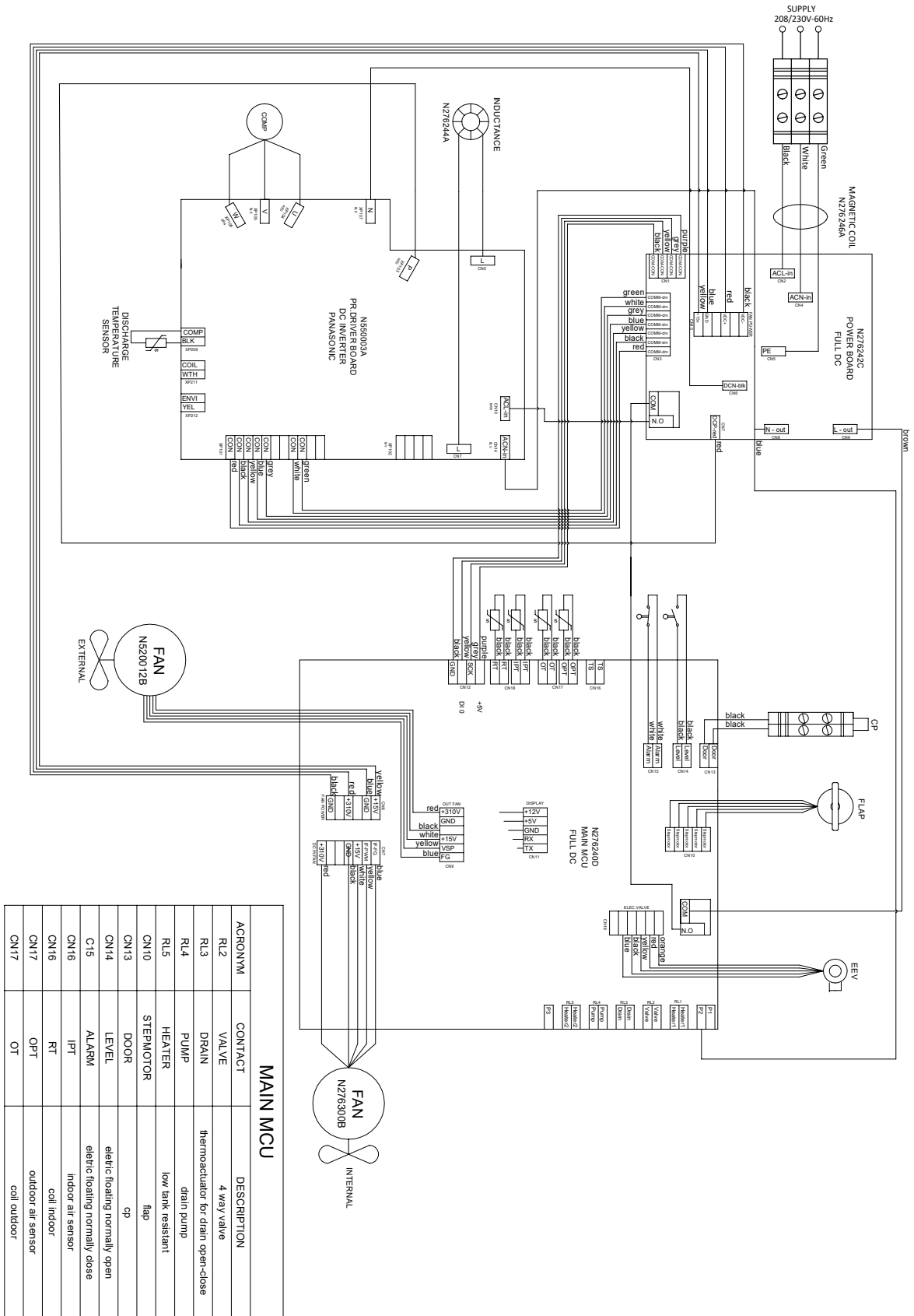

Mounting template

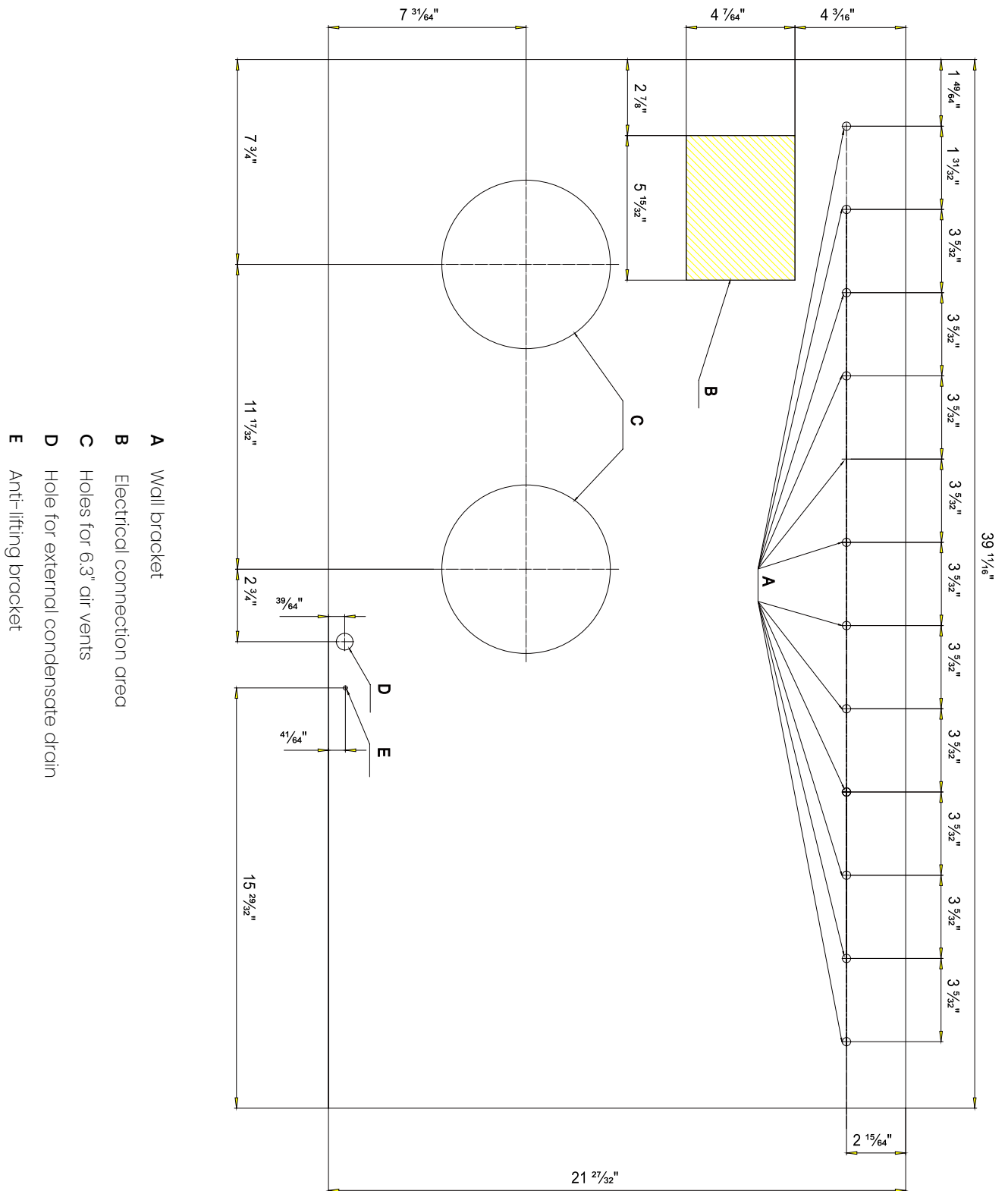

- A** Wall bracket
- B** Electrical connection area
- C** Holes for 6.3" air vents
- D** Hole for external condensate drain
- E** Anti-lifting bracket



With over 15 years of experience in the climate comfort sector, we have a clear goal: growth through innovation. Our team is laser-focused on the conception, development, and production of innovative heating, ventilation, and air conditioning solutions. This mission has developed through bringing together technical skills, creativity, technology, design, Italian passion, and a global vision to achieve the best energy efficiency and performance.

Ephoca is the US subsidiary of Innova SRL - Via 1° Maggio, 8 - 38089 Storo (TN) Italy.

ephoca.com | 216-710-1000



MADE IN ITALY